



# MANUAL CUTTING MACHINES



SMALL CUTTING MACHINES WITH  
POWER AND ENDURANCE FOR  
INDUSTRY AND HANDCRAFT

ERGONOMIC

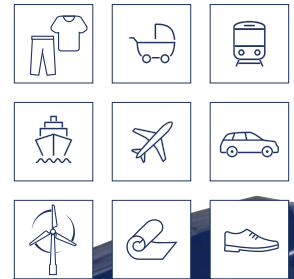

## INNOVATIVE PRODUCTS IN HIGH-TECH QUALITY

It is difficult to imagine cutting and spreading without Kuris handheld cutting machines. The machine has to cater for the operator's method of working and not the other way round!



## INTRODUCTION

### Novita rotating blade machines

Novita-Standard .....	4 – 5
Novita-Plus .....	6 – 7
Novita-Super .....	8 – 9

### Rechargeable rotating blade machine and scissors

MB-60 .....	10 – 11
MCUT-8 .....	12 – 13

### BOM rotating blade machines

BOM 30 .....	14 – 15
BOM 101 / S / Power .....	16 – 17
BOM 101 Akku .....	18 – 19

### KRS rotating blade and four-arc blade machine

KRS 550 .....	20 – 21
---------------	---------

### KSM rotating blade machine

KSM 200 L / R .....	22 – 23
---------------------	---------

### KVS/KV straight-knife cloth cutters

KVS 700 .....	24 – 25
KVS 900 .....	26 – 27
KV 1505 E .....	28 – 29

### All machines are VDE-tested!

Reproduction, inclusion in online services as well as distribution on data carriers is only permitted with the permission of Kuris Spezialmaschinen GmbH. Errors and omissions excepted.

## SMALL CUTTING MACHINES (round) MAKE THE STEP TOWARDS A BETTER CUT

Fit in the cutting industry starts with accurately cut material or technical textiles. Seldom has a handheld cutting tool been so keenly tailored to the cutter. Cutting thick layers, into tight corners, at acute angles - this is precisely what the machines are designed for. The quality of the cut - that is decided by the cutter and the cutting blade. Kuris' new small cutting machines glide easily through the fabric; they produce a cleaner cut and are more manageable.

Today, rotating blade machines are used primarily for straight, long cross cuts. Thanks to the smooth, clean cut they are excellently suited to knitted goods and knitwear as well as linings and other materials that are susceptible to fraying and the build-up of fluff. There are also various applications in the manufacture of upholstered furniture and mattresses (cutting upholstery and diol fabrics etc.) in felt, cotton wool and dressing material, blanket, carpet and bodywork factories. The rotating blade gets its cutting effect in combination with the jaw with knife-edged joints fitted to the base plate. The integrated grinding device resharpenes the blade. Steel blades with a higher service life can be supplied for extreme loads. The finger guard provides safety when cutting and offers protection against injuries.

The drive motors can be designed for DC and AC current. If required, Kuris rotating blade machines can be fitted with a four-arc knife and counter blade for cutting plastic material

and rubber etc. The special half-speed or multiple speed motor is then recommended. The machine can then be fitted with a blade damping device to prevent the knife from becoming encrusted with cutting residues.

## STRAIGHT-KNIFE CLOTH CUTTERS (vertical) SHARP, QUICK, CONVENIENT APPLICATION. EASY AND RELIABLE TO OPERATE.

Kuris straight-knife cloth cutters with cutting heights of 70 to 210 mm are ideal tools for all cutting operations. From pattern-making through to cutting multiple layers, they are suitable for all flexible surface structures, such as textiles, knitwear and knitted goods, technical textiles and special materials, such as films, felt, Skai, branded films and soft leather etc.

The machines excel in being able to keep to the curves. Thanks to its particularly narrow and low construction, the machine provides good visibility of the blade. A special coating offers excellent glide properties and considerable wear resistance.

Sliding handle, carrying handle, presser handle, ON / OFF switch and sharpening tool activation are optimally configured. The machines are carefully balanced and easy to manage. Whoever works with them feels they are an extension to themselves. The blade is sharpened on both sides as it is lifted up and down. Unusually even and exact. The layers of material are therefore always cut cleanly, free from fraying right down to the bottom layer of material.

An important feature (especially with the KVS 900) is, that it is not possible for the grinding equipment drive to be damaged when the grinding attachment comes up against an obstacle (e.g. layer of material).

WHO NEEDS THESE STRONG AND FLEXIBLE MACHINES? Ladies', gentlemen's and children's clothing, sports and professional clothing factories, linen, knitwear and hosiery production, stocking makers, bed linen, bed and quilt makers, curtain and home décor material production and the entire home decoration sector, upholstered furniture industry, saddlers, tanneries, leather manufactures, glove manufactures, hat and bonnet production, toys and dolls' clothes manufacture.

Workshop of public authorities, hospitals, weaving mills, home textiles, tie manufactures, handcraft industry, slipcover manufacturers, dockyard and ship rigging, carpet factories, large book binders, fiber glass processing companies, woven felt factories, automotive, shoe-makers, pushchair manufacturers, manufacturers of camping articles, caravan manufacturers, fur processors, paper board factories, office furniture manufacturers and fisheries.

Several advantages at a glance:

- + Excellent handling
- + Lower cutting resistance
- + Lower power requirement
- + Better around curves
- + Higher cutting speed

# NOVITA Standard

There is the option of three bases, depending on the application:

33283 – Novita Standard with flat base

33284 – Novita Standard with skid base

33289 – Novita Standard with skid base with protective ball



Novita Standard



Novita Super



Novita Plus

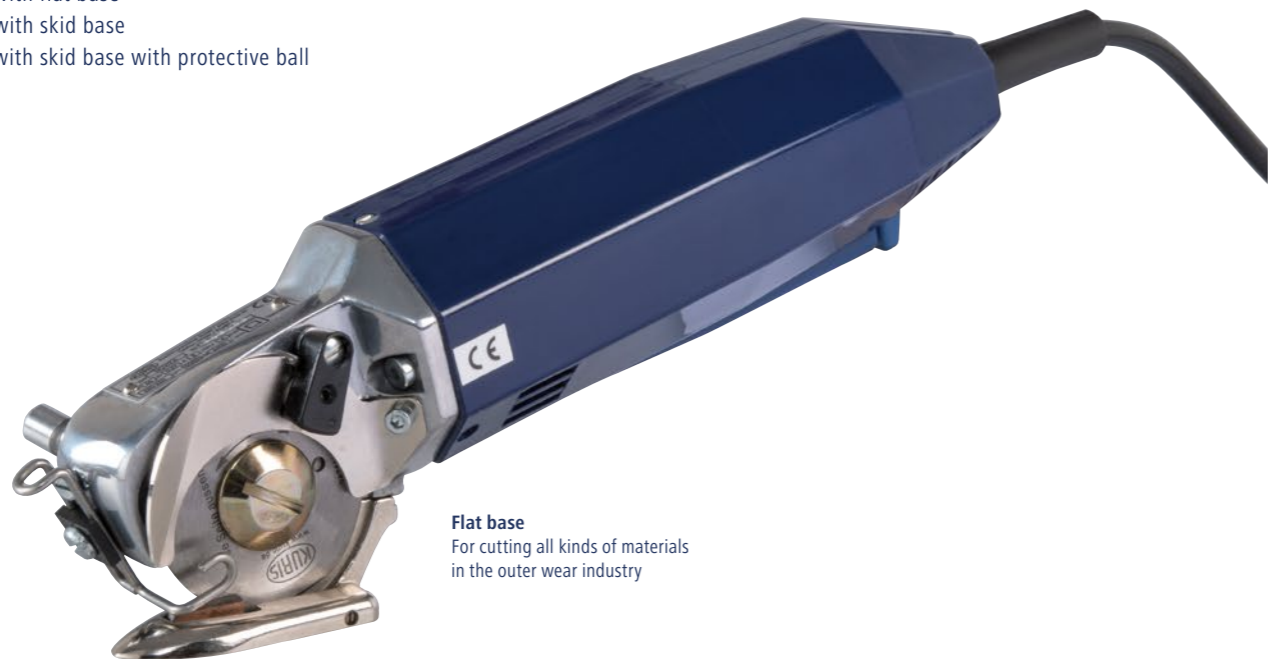

**Flat base**  
For cutting all kinds of materials  
in the outer wear industry

## APPLICATION AREA

Effortlessly clean and without considerable technical investment you are therefore able to cut all manner of textiles and soft leather. There are applications for single layer and multiple layer cutting, particularly for cutting templates and patterns. Also ideal for trimming defective parts, for cutting knitwear and knitted goods straight and curtains, upholstery and decorative fabrics true to form, even for an unconventional application. Icelandic fishermen separate the tail fins of plaice and other fish, using the Novita Standard. The lubricator decreases friction between the blade and counter blade, enabling laminated goods to be cut.

The Novita Standard is fully insulated and VDE tested. A special combination gear mechanism gives the machine a unique motor speed strength across the entire load range. The motor only gets moderately warm, preventing overload and guaranteeing the highest protection and service life. The blade guard is easily and infinitely adjustable and does not obscure blade visibility. The operating handle for the grinding device has been shaped in such a way, that the blade can be sharpened using one hand, even during the cutting operation. Handling and management of the machine is easy and balanced.

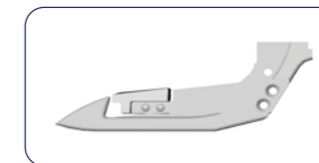

**25508 - Skid base**  
For cutting thicker materials (upholstery etc.) and for an exact template cut.

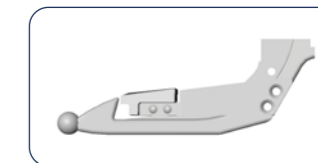

**28456 - Skid base with protective ball**  
For cutting delicate materials (no fiber damage).

## TECHNICAL DATA

Motor power: .....	approx. 56 Watt
Motor data: .....	220 V / 50 Hz
Duty cycle: .....	60 % (not for continuous operation)
Motor speed (idle): .....	approx. 11,000 rpm
Blade speed (idle): .....	approx. 2,600 rpm
Blade diameter: .....	50 mm
Blade wear limit: .....	approx. 42 mm
Cutting height, max.: .....	8 mm
Motor diameter: .....	approx. 50 mm
Machine length: .....	approx. 230 mm
Machine weight, excl. cable: .....	approx. 850 g
Vibration: .....	< 2.5 m/s
Running noise: .....	73 dB(A)

# NOVITA Super

33294 – Novita Super with flat base



Novita Standard

Novita Super

Novita Plus



**Flat base**  
For cutting all kinds of materials in the outer wear industry

**78825 – Prolongation handle (80cm long)**  
The machine is also available with a prolongation handle.

## APPLICATION AREA

The „Novita Super“ provides concentrated force to withstand heavy and even the most difficult of loads. The cutting performance is 10x greater than that of the Novita Standard version. Particularly handy and lightweight machine for cutting all types of material in layers up to approx. 8 mm high, depending on the material.

Particularly suitable for needled felt, Skai, branded films, soft leather and upholstery cover materials. The lubricator reduces friction between the blade and the counter blade, enabling laminated goods to be cut.

Cutting machine for template and pattern making, cutting single layers, re-cutting defectives parts, straight cutting true to form, light load (outer wear materials, knitted goods and knitwear, curtain, upholstery and decoration fabrics etc.).

The blade protection in signal color can be adjusted easily and infinitely and does not constrict the visibility. The actuating lever for the grinding device is well shaped, so that the blade can be re-sharpened with one hand even during cutting. Handling and guidance of the machine is easy and balanced.

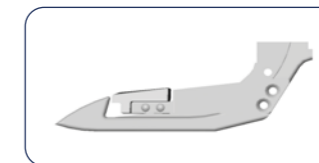

**25508 - Skid base**  
For cutting thicker materials (upholstery etc.) and for an exact template cut.

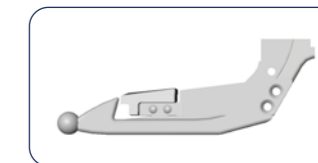

**28456 - Skid base with protective ball**  
For cutting delicate materials (no fiber damage).

## TECHNICAL DATA

Motor power: .....	approx. 56 Watt
Motor data: .....	220 V / 50 Hz
Duty cycle: .....	60 % (not for continuous operation)
Motor speed (idle): .....	approx. 12,000 rpm
Blade speed (idle): .....	approx. 1,500 rpm
Blade diameter: .....	50 mm
Blade wear limit: .....	approx. 42 mm
Cutting height, max.: .....	8 mm
Motor diameter: .....	approx. 50 mm
Machine length: .....	approx. 260 mm
Machine weight, excl. cable: .....	approx. 1,000 g
Vibration: .....	< 2.5 m/s
Running noise: .....	73 dB(A)

# NOVITA Plus

56715 – Novita Plus with flat base



**Flat base**  
For cutting all kinds of materials  
in the outer wear industry

## APPLICATION AREA

A particularly convenient and lightweight machine for cutting all kinds of textiles for layers and up to approx. 8 mm high, depending on the type of material. Especially suitable for wool and soft materials. Either the flat base or the cutting skid may be used. The lubricator decreases friction between the blade and counter blade, enabling laminated goods to be cut.

The Novita Plus is fully insulated and VDE tested. A special combination gear mechanism gives the machine a unique motor speed strength across the entire load range. The motor only gets moderately warm, preventing overload and guaranteeing the highest protection and service life. The blade guard is easily and infinitely adjustable and does not obscure blade visibility. The operating handle for the grinding device has been shaped in such a way, that the blade can be sharpened using one hand, even during the cutting operation. Handling and management of the machine is easy and balanced.

## TECHNICAL DATA

Motor power:	..... approx. 56 Watt
Motor data:	..... 220 V / 50 Hz
Duty cycle:	..... 60 % (not for continuous operation)
Motor speed (idle):	..... approx. 12,400 rpm
Blade speed (idle):	..... approx. 3,000 rpm
Blade diameter:	..... 50 mm
Blade wear limit:	..... approx. 42 mm
Cutting height, max.:	..... 8 mm
Motor diameter:	..... approx. 50 mm
Machine length:	..... approx. 230 mm
Machine weight, excl. cable:	..... approx. 850 g
Vibration:	..... < 2.5 m/s
Running noise:	..... 73 dB(A)



## RECHARGEABLE CUTTING MACHINE MB-60

68032 – Rechargeable cutting machine MB-60

68155 – Additional battery



**Flat base**  
For cutting all kinds of materials  
in the outer wear industry

**78725 – Prolongation handle (80cm long)**  
The machine is also available  
with a prolongation handle.

### APPLICATION AREA

The rechargeable cutting machine MB-60 offers the user considerably greater mobility and convenience during operation. The particularly convenient and lightweight machine is suitable for cutting all kinds of textiles for layers up to approx. 8 mm high, depending on the type of material.

Also ideal for wool and soft materials. The lubricator reduces friction between the blade and the counter blade, enabling laminated goods to be cut.

The machine offers a good mechanical operating ratio. At the fore are the MB-60's compact size and light weight.

Quick battery changes are very easy. The machine comes with a charger as standard.



68157 Charger MB-60-52

### TECHNICAL DATA

Motor voltage: ..... 9.6 V  
Motor speed (idle): ..... 1,200 rpm  
Weight (incl. battery): ..... 1.2 kg  
Battery type: ..... NiCad  
Rated voltage: ..... 9.6 V  
Capacity: ..... 1.2 Ah  
Battery weight: ..... approx. 500 g



## MCUT-8

112270 - MCUT-8



### APPLICATION AREA

The MCUT-8 is a compact and powerful cordless hand cutting machine for precise cutting of textiles and light technical materials. Its ergonomic design and easy handling make it comfortable to use and reduce fatigue, even during longer periods of work.

The machine is ideal for sample and pattern cutting, single-ply cutting, as well as rework and corrections. It delivers clean and accurate cutting edges and is particularly suitable for materials such as cotton, lightweight fabrics, films, leather, paper, and similar materials.

Thanks to modern Li-ion battery technology, the MCUT-8 offers high flexibility in daily operations. The powerful battery ensures reliable runtimes and can be conveniently charged via USB-C, allowing for fast and easy charging, even on the go and independent of fixed power sources.

The machine stands out for its low weight and ease of handling. It is suitable for a wide range of applications in industry, crafts, and workshops, supporting efficient work across various use cases.

### TECHNICAL DATA

Charger: .....	USB-C, 5 V / 2 A
Motor speed (idle): .....	6,000 rpm
Cutting height, max.: .....	approx. 8 mm
Weight (incl. battery): .....	approx. 390 g
Battery capacity: .....	4,600 mAh

# BOM 30

33028 – BOM 30



BOM 30



BOM 101



BOM 101 Akku



33066 - BOM 30 SL with extension (85cm long)

40130 - BOM 30 SK

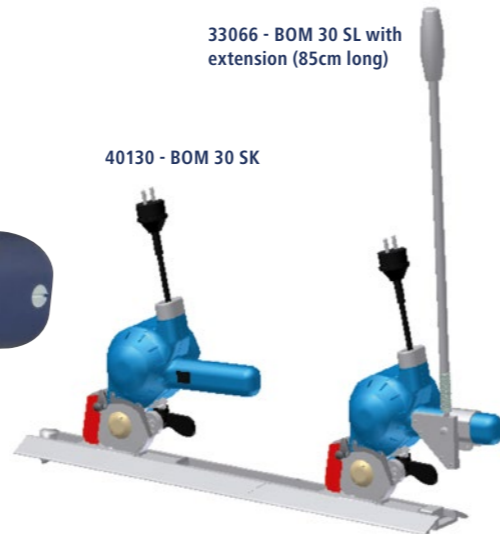

The BOM 30 SK and BOM 30 SL versions are supplied with a special base that is fed into an aluminium profile track. The BOM 30 SL with the extension and automatic ON/OFF switch is particularly suitable for trimming endless fabric.

## APPLICATION AREA

A particularly convenient and lightweight machine for cutting all kinds of textiles for layers up to approx. 25 mm high, depending on the type of material. Especially suitable for wool and soft materials. The lubricator reduces friction between the blade and the counter blade, enabling laminated goods to be cut. For universal use for cutting single and multiple layers, light to medium load (traditional clothing materials, such as knitted goods, knitwear and decorative fabrics etc.). Also available with an extension (also with automatic ON/OFF switch) and special base for aluminium track for trimming endless fabric.

With the BOM 30 series of electric handheld cutters, the cutting effect is produced by a six-arc blade in conjunction with a spring-loaded adjacent counter blade. This cutting principle enables good cutting performance at relatively low blade speeds. Individual layers of the finest materials and layers of material up to a cutting height of 25 mm can be cut equally well. High traction force thanks to a robust motor with a high power margin. Optimal blade propulsion across synchronous belts and cylindrical gears with excellent operating efficiency. Practically maintenance-free thanks to a special seal. Highest performance and service life due to very low heat generation in the motor and gears.

Sturdy reliability thanks to the spring-loaded counter blade. With carbide counter blade and HSS blade for heavy materials on request. Every machine possesses an adjustable finger guard based on employers' liability insurance regulations. Not susceptible to contaminants, threads and fluff thanks to the special development and construction of the support and gear mechanism housing.

## TECHNICAL DATA

Motor power BOM 30 / BOM 30 S:	approx. 140 Watt
Motor data:	230 V / 50 Hz
Duty cycle:	60 % (not for continuous operation)
Motor speed (idle):	approx. 8,000 rpm
Blade speed (idle):	approx. 1,000 rpm
Blade diameter:	80 mm
Blade wear limit:	approx. 72 mm
Cutting height, max.:	approx. 25 mm
Machine weight, excl. cable:	approx. 2.2 kg
Vibration:	< 2.5 m/s
Running noise:	73 dB(A)

# BOM 101

54586 – BOM 101  
49095 – BOM 101 Power



BOM 30



BOM 101



BOM 101 Akku



Extension = 85cm  
56028 - BOM 101 SL Power  
54589 - BOM 101 SL

56027 - BOM 101 SK Power  
54588 - BOM 101 SK



The BOM 101 SK and BOM 101 SL versions are supplied with a special base that is fed into an aluminum profile track. The BOM 101 SL with the extension and automatic ON/OFF switch is particularly suitable for trimming endless fabric.

## APPLICATION AREA

A particularly convenient and lightweight machine for cutting all kinds of textiles for layers up to approx. 25 mm high, depending on the type of material. The fortified „Power“ versions particularly suitable for jeans, leather and rigid fabrics as well as industrial fabrics. The lubricator reduces friction between the blade and the counter blade, enabling laminated goods to be cut.

With the BOM 101 series of electric handheld cutters, the cutting effect is produced by a four-arc or six-arc blade in conjunction with a spring-loaded adjacent counter blade. This cutting principle enables good cutting performance at relatively low blade speeds. Individual layers of the finest materials and layers of material up to a cutting height of 27 mm can be cut equally well. High traction force thanks to a robust motor with a high power margin. Optimal gear mechanism made from a special alloy with excellent operating efficiency and simple maintenance. Practically maintenance-free thanks to a special seal. Highest performance and service life due to very low heat generation in the motor and gears.

Not susceptible to contaminants, threads and fluff thanks to the special development and construction of the support and gear mechanism housing.

Light handling and handy machine controls in all cutting positions thanks to the „bone grip“. Grinding device very easy to operate thanks to the ideal configuration of the operating element. Optimal view of the workpiece thanks to the oval shape of the housing. Very low running noise. Quick blade change thanks to easy and very accessible blade fixing.

## TECHNICAL DATA

Motor power BOM 101:	..... approx. 140 Watt
Motor data:	..... 230 V / 50 Hz
Duty cycle:	..... 60 % (not for continuous operation)
Motor speed (idle):	..... approx. 8,000 rpm
Blade speed (idle):	..... approx. 1,000 rpm
Blade diameter:	..... 80 mm
Blade wear limit:	..... approx. 72 mm
Cutting height, max.:	..... approx. 27 mm
Machine weight, excl. cable:	..... approx. 2.2 kg
Vibration:	..... < 2.5 m/s
Running noise:	..... 73 dB(A)

## BOM 101 AKKU

- 69409 – BOM 101 Akku 2 Ah
- 80700 – BOM 101 Akku 2 AH SL (guided in a profile track, extension)
- 74839 – BOM 101 Akku 3 Ah



BOM 30



BOM 101



BOM 101 Akku

Each machine complete with  
1 charging unit and 1 battery

- 69026 – Battery 2 Ah (spare) (charge time: 1,5 h, 664 g)
- 67225 – Battery 3 Ah (spare) (charge time: 1,75 h, 722 g)
- 69093 – Charging unit



### APPLICATION AREA

A particularly convenient and lightweight machine for cutting all kinds of textiles for layers up to approx. 27 mm high, depending on the type of material. The lubricator reduces friction between the blade and the counter blade, enabling laminated goods to be cut.

With the BOM 1010 series of electric handheld cutters, the cutting effect is produced by a four-arc or six-arc blade in conjunction with a spring-loaded adjacent counter blade. This cutting principle enables good cutting performance at relatively low blade speeds. Individual layers of the finest materials and layers of material up to a cutting height of 27 mm can be cut equally well. High traction force thanks to a robust motor with a high power margin. Optimal gear mechanism made from a special alloy with excellent operating efficiency and simple maintenance. Practically maintenance-free thanks to a special seal. Highest performance and service life due to very low heat generation in the motor and gears.

Not susceptible to contaminants, threads and fluff thanks to the special development and construction of the support and gear mechanism housing.

Light handling and handy machine controls in all cutting positions thanks to the „bone grip“. Grinding device very easy to operate thanks to the ideal configuration of the operating element. Optimal view of the workpiece

thanks to the oval shape of the housing. Very low running noise. Quick blade change thanks to easy and very accessible blade fixing. The advantage of BOM 101 Akku in relation to BOM 101 series is the independence through the battery.

### TECHNICAL DATA

Motor power BOM 101 Battery powered: .....	approx. 140 Watt
Motor data: .....	12 V
Duty cycle: .....	60 % (not for continuous operation)
Motor speed (idle): .....	approx. 11,000 rpm
Blade speed (idle): .....	approx. 900 rpm
Blade diameter: .....	80 mm
Blade wear limit: .....	approx. 72 mm
Cutting height, max.: .....	approx. 27 mm
Machine weight, excl. cable: .....	approx. 1.75 kg without battery / gross 5.00 kg
Vibration: .....	< 2.5 m/s
Running noise: .....	73 dB(A)

## KRS 550

- 33425 – KRS 550 R (rotating blade)
- 33453 – KRS 550 V (four-arc blade)
- 80646 – KRS 550 R for guide rail (BOM 101 profile track))
- 75786 – KRS 550 V for guide rail (BOM 101 profile track))



KRS 550 R

### APPLICATION AREA

The KRS 550 model of the Kuris cutting machines can be supplied as a rotating blade or a four-arc machine with counter blade. It is possible to convert a rotating blade machine to a four-arc blade machine or vice versa using an appropriate unit.

KRS 550 with rotating blade:

1. For cutting all kinds and designs of textile materials.
2. Particularly suitable for cutting knitwear and knitted goods and quilted materials that tend to fray easily or produce fluff.

KRS 550 with four-arc blade and counter blade, for cutting

1. synthetic material that tend to be over a certain height for bonding cut edges.
2. plastic materials (Skai, branded films, etc.).
3. laminated flooring.
4. synthetic rubber interwoven materials (also rubber or soft rubber up to a certain height).

The KRS 550 can be fitted with a blade damping device to prevent the blade from becoming encrusted with cutting residues. A Teflon-coated blade is recommended for cutting particularly critical material.

	AC 400V, 50 Hz	change-pole 400V, 50 Hz	
<b>Motor power Watt</b>	370	200	280
<b>Engine speed rpm</b>	2,800	1,400	2,800
<b>Blade speed rpm</b>	1,140	570	1,140

### TECHNICAL DATA

Blade diameter: ..... 120 mm  
 Blade wear limit: ..... approx. 93 mm  
 Cutting height, max.: ..... approx. 55 mm  
 Machine weight: ..... approx. 10.5 kg  
 Running noise: ..... < 70 dB(A)

## KSM 200 Q L/R

- 33326 – KSM 200 Right (rotating blade)
- 33327 – KSM 200 Left (rotating blade)
- 53648 – KSM 200L Cross cutter (four-arc blade)
- 53647 – KSM 200L Left (four-arc blade)
- 53646 – KSM 200L Right (four-arc blade)

53647 KSM 200L Left

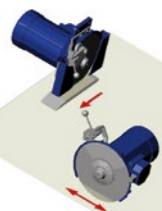

53648-KSM 200L Q



33327- KSM 200 Left



53646-KSM 200 L Right



33326-KSM 200 Right

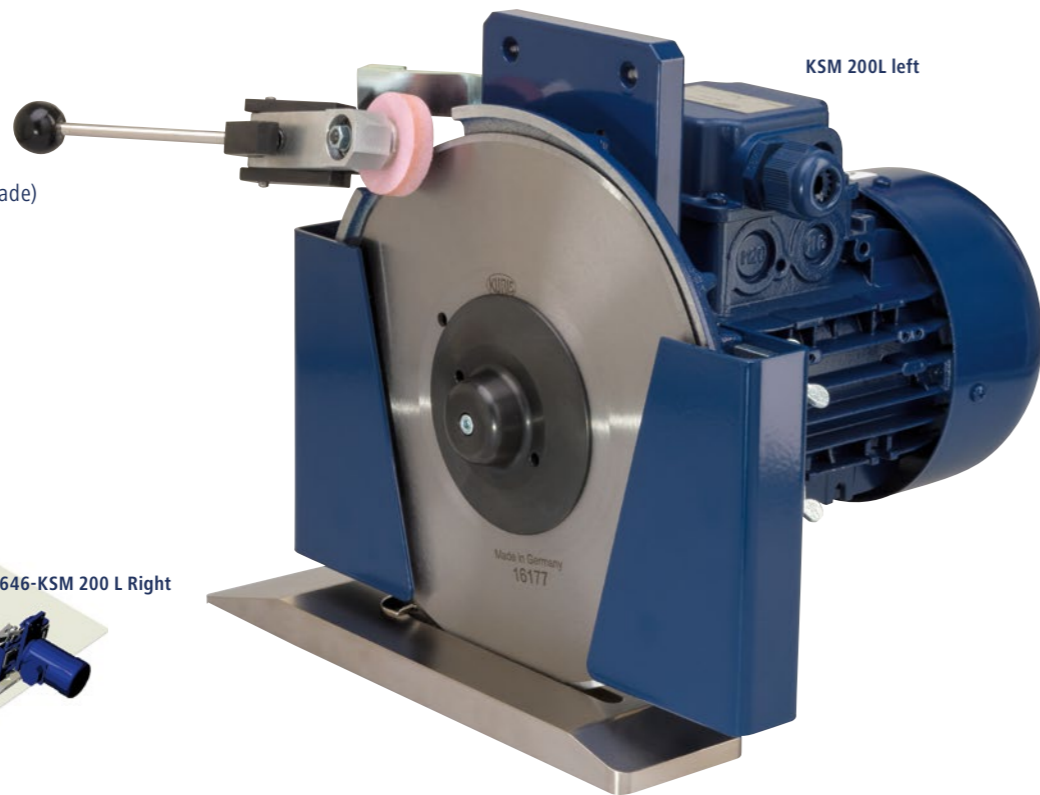

KSM 200L left

### APPLICATION AREA

Edge and middle cutters for special applications, individual customer solutions or special machine construction.

#### KSM 200 in left-hand and right-hand design

The KSM 200 machines have a rotating blade made from tool steel, a grinding device with two sharpening edges and no base plate. We recommend the rotating blade in HSS quality for certain types of cut.

You can distinguish between left and right by looking at the machine from the side of the blade. If the grinding device is located on the left, this is a left-hand version. If the grinding device is located right, this is a right-hand version.

#### KSM 200 L in left-hand and right-hand version

The „L“ stands for lengthways cutter. Even this machine is constructed in a left- and right-hand version, i.e. for use as a pair for trimming endless fabric etc. The KSM 200 L possesses an HSS quality four-arc blade, a co-ordinated unilateral grinding device and a base plate with counter blade, i.e. it can only cut in one direction.

#### KSM 200L Q

The „Q“ stands for cross cutter. This machine also has an HSS quality four-arc blade, unilateral grinding device and, in contrast to the KSM 200 L model, a base plate with two counter blades, enabling the KSM 200 Q model to cut in both directions.

	Standard version	1. Option (on request)
<b>Motor data</b>	0,37kW 230/400V 2.2/1.27A 50Hz	0,30kW 230/400V 1.61/0.92A 50(60)Hz
<b>RPM</b>	1350 1/min	2,800 1/min (3335 rpm)

### TECHNICAL DATA

Motor power: ..... 0.37 kW  
 Blade diameter: ..... 200 mm  
 Cutting height, max.: ..... 22 mm with protection / 40 mm without protection  
 Machine weight: ..... 9.5 kg

# KVS 700

33530 – KVS 700 E  
57694 – KVS 700 UVV



KVS 700 UVV

## APPLICATION AREA

The ideal machine for all cutting operations, from pattern making to cutting multiple layers, with maximum cutting heights of 8 to 210 mm, for flexible surface structures such as textile fabrics, knitted goods and knitwear, technical textiles and special materials such as films, felt, Skai branded films and soft leather etc.

The KVS 700 straight-knife cloth cutter bridges the former gap between electric handheld cutting machines and conventional straight-knife cloth cutters for thick layers. An electric handheld cutting machine with rotating blade will have problems cutting acute angles and tight curves at certain layer heights. In contrast, even darts, necklines and similar can be cut out using a single-knife cloth cutter.

The base plates for the Kuris straight-knife cloth cutters are provided with a special coating. This offers excellent glide properties and high wear resistance.

## Benefits:

The good cutting performance is the result of the high stroke rate of the blade, the tips of which only project a little way from the base plate, making it possible to achieve a clean cut for a smaller number of layers. The grinding equipment is semi-automatic, i.e. the two grinding discs are power driven and the grinding device is lifted by hand. The blade driving mechanism and guide have been optimized. All the rotation parts run on ball bearings. The machine is therefore virtually maintenance-free.

## TECHNICAL DATA

Motor power: ..... approx. 140 Watt  
 Motor data: ..... 220-250 V WS 50/60 Hz  
 Cutting height, max.: ..... approx. 70 mm  
 Knife stroke: ..... 12 – 15 – 18 mm  
 Machine weight, excl. cable: ..... 6 kg

# KVS 900

33866 – KVS 900 E direct current  
57696 – KVS 900 UVV direct current



KVS 700      KVS 900      KV 1505 E



KVS 900 E

## APPLICATION AREA

The KVS 900 straight-knife cloth cutter is the machine for the job. Ideally suited to cutting every type and design of textile material, though particularly for cutting thick layers, tight curves and acute angles.

Straight-knife cloth cutter for average layer heights, even for difficult to cut materials, high cutting accuracy thanks to the very small dimensions of the base plate, support and blade, fatigue-proof work with quiet running, good overview and low weight.

We play it safe when it comes to safety. Just like all Kuris models, the Kuris KVS 900 meets the relevant safety standards. Possible sources of danger are already ruled out at the design stage. Therefore the presser foot bar with only a 13 mm gap from the blade takes on an additional function as a blade guard.

An important feature (especially with the KVS 900) is that it is not possible for the grinding device drive to be damaged when the grinding device comes up against an obstacle (e.g. a layer of material).

The very high lifting speed of the grinding head at approx. 1 s per sharpening operation reduces sharpening times quite considerably, making it possible for the grinding wheel to reach an optimum of 7 rpm. The blade is sharpened on both sides as it is lifted up and down. Unusually even and

exact. The layers of material are therefore always cleanly cut, free from fraying right down to the bottom layer of material.

### Benefits:

- + Exact, sharp cut thanks to the automatic grinding device with whetstones
- + Sturdy special motor with a high power margin
- + Narrow supports reduce effort
- + Low base plate with a special surface minimizes slide resistance

## TECHNICAL DATA

Motor power: .....	0.37 kW
Duty cycle: .....	60 % (not for continuous operation)
Blade speed (idle):.....	2,800 rpm
Cutting height, max.: .....	90 mm
Knife stroke: .....	36 mm
Machine weight: .....	approx. 8.4 kg
Vibration: .....	2.5 m/s
Running noise: .....	70 dB(A)



# KV 1505 E

112268 – KV 1505 E  
112550 – Safety upgrade (UVV)



KVS 700    KVS 900    KV 1505 E



KV 1505 E

### APPLICATION AREA

The straight knife cutting machine is suitable for cutting all types of textile materials. It is particularly designed for cutting high layers, tight curves, and sharp angles, even under heavy-duty conditions. It is ideal for all types of apparel fabrics and virtually all technical textiles.

#### Benefits:

The machine features an automatic sharpening system, is largely maintenance-free, and easy to handle.

- + Precise, sharp cutting due to automatic sharpening device with grinding belts
- + Robust special motor with high power reserve
- + Slim support arm to reduce operating effort
- + Low base plate with special surface to minimize friction
- + Machine equipped with knife guard for enhanced safety



High layer cutting



Automatic sharpening device with grinding belts

### TECHNICAL DATA

Motor: ..... 3-phase / 50 Hz  
 Motor speed: ..... approx. 2,850 rpm  
 Cutting height, max.: ..... approx. 150 mm  
 Weight: ..... 18 kg



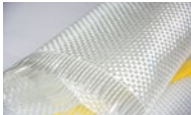

### Application area of our Machines:

- + Apparel
- + Automotive
- + Technical textile
- + Upholstery
- + Aerospace
- + Shipbuilding
- + Railway
- + Building sector
- + Renewable Energy (Wind energy / Solar)
- + Handcraft

The comprehensive product range also allows solutions tailored to your particular needs. In our showroom, spreading and cutting machines are available both for general demonstrations and for testing with your own materials. **Arrange an appointment with us.**

**We will be delighted to advise you!**

### Kuris Spezialmaschinen GmbH

Degginger Straße 6  
D-73326 Deggingen - Reichenbach

Fon: +49 (0) 73 34 - 9 24 80 - 0  
Fax: +49 (0) 73 34 - 9 24 80 - 69  
E-Mail: [info@kuris.de](mailto:info@kuris.de)